

The AC-Enhancer™ Field Blower Relay Addition for Trane TEH Air Handler

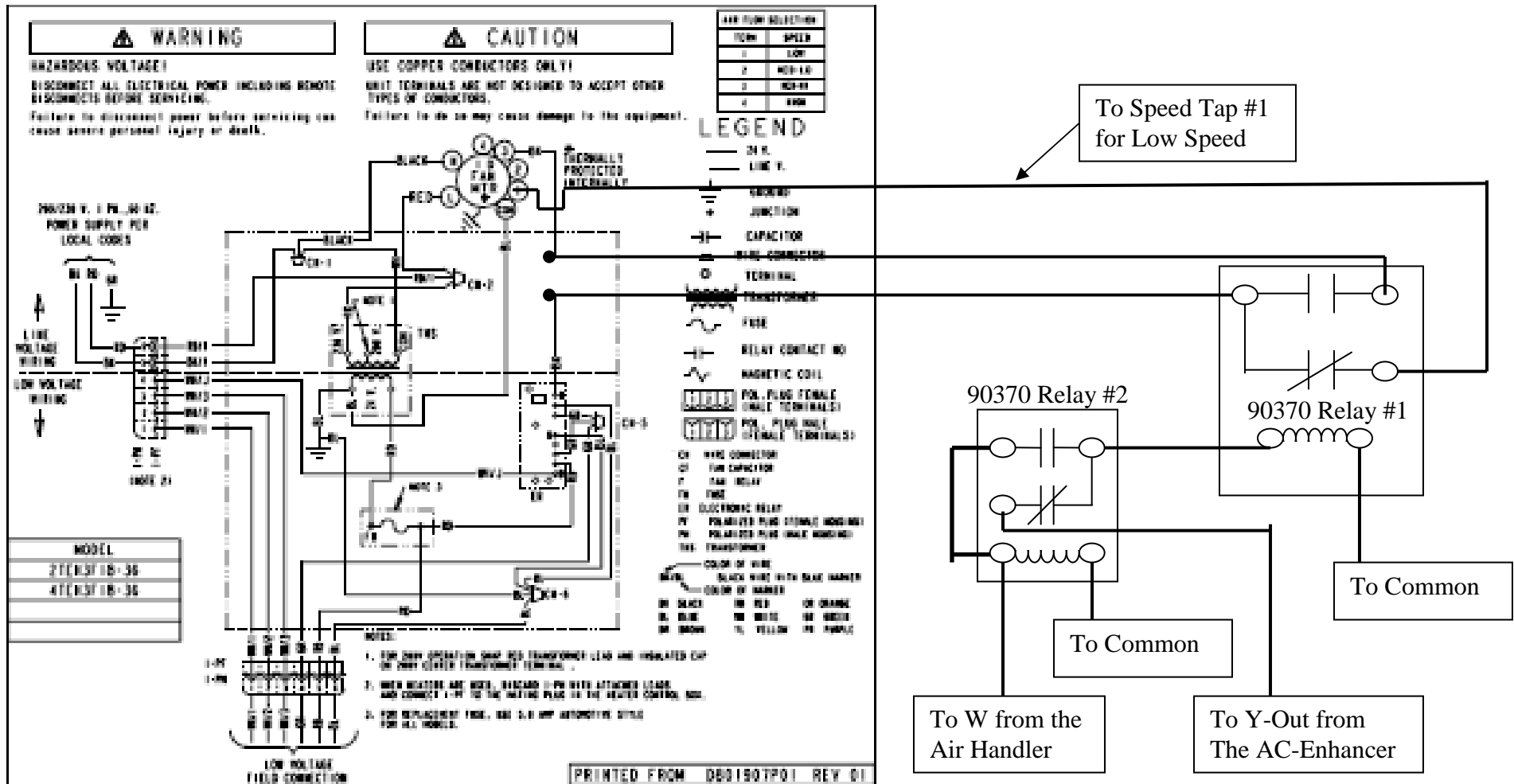

Cut Black blower speed wire from circuit board and splice across the normally open set of points on the 90370 relay #1 added to the system. Make sure that the wire from the circuit board is connected to terminal #4 on the relay and the wire going to the motor speed tap #3 is on Terminal #2. Add a wire from the normally closed set of points (Terminal #5) to speed tap #1 for low blower speed. 90370 Relay #2 is added to allow the system to run on high blower speed when in the heating mode.